

# Pegasus-T Special Application

## *Calibrating Short Sensors at High Temperatures*

2020 Updates

Issue 01.01

The Pegasus-T is the latest member of the Pegasus family developed for sensors that are simply too short to be calibrated in the Pegasus 4853 or other conventional calibration furnaces



**ISOTECH** 40 years  
1980-2020

# ISOTECH

## INTRODUCING ISOTECH

A world leader in temperature metrology  
Celebrating 40 years in business 1980 - 2020  
Holds Queen's Award for Enterprise in the  
Innovation Category





# Isotech Calibration Solutions from Primary Standards to Industrial Sensors

---

*The world's leading National Metrology  
Institutes choose Isotech – shouldn't you?*

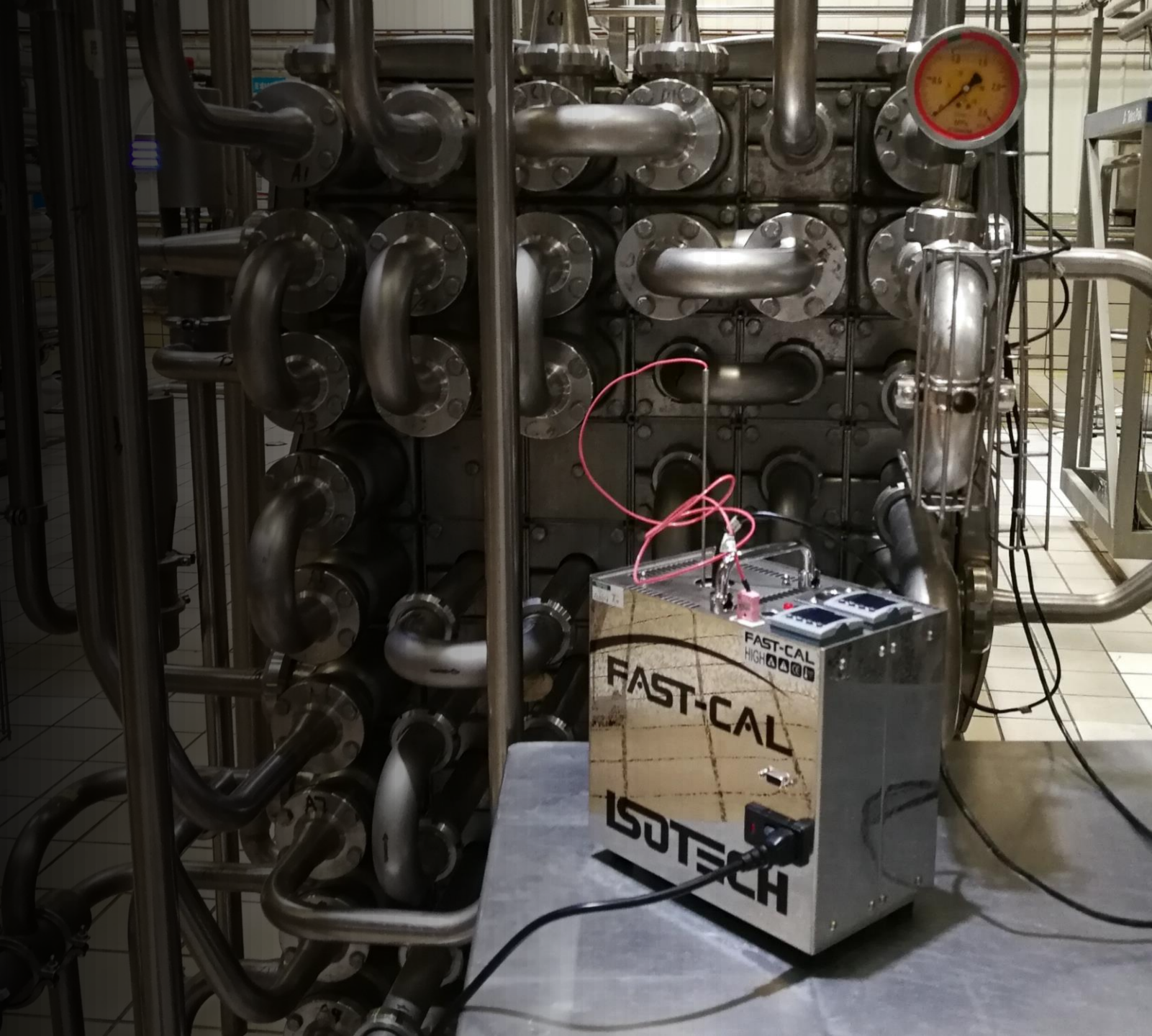

## CONFIDENCE IN ISOTECH

Isotech are accredited to calibrate to the smallest of uncertainties

UKAS Schedule, full Details: <https://bit.ly/ISO-UCT>

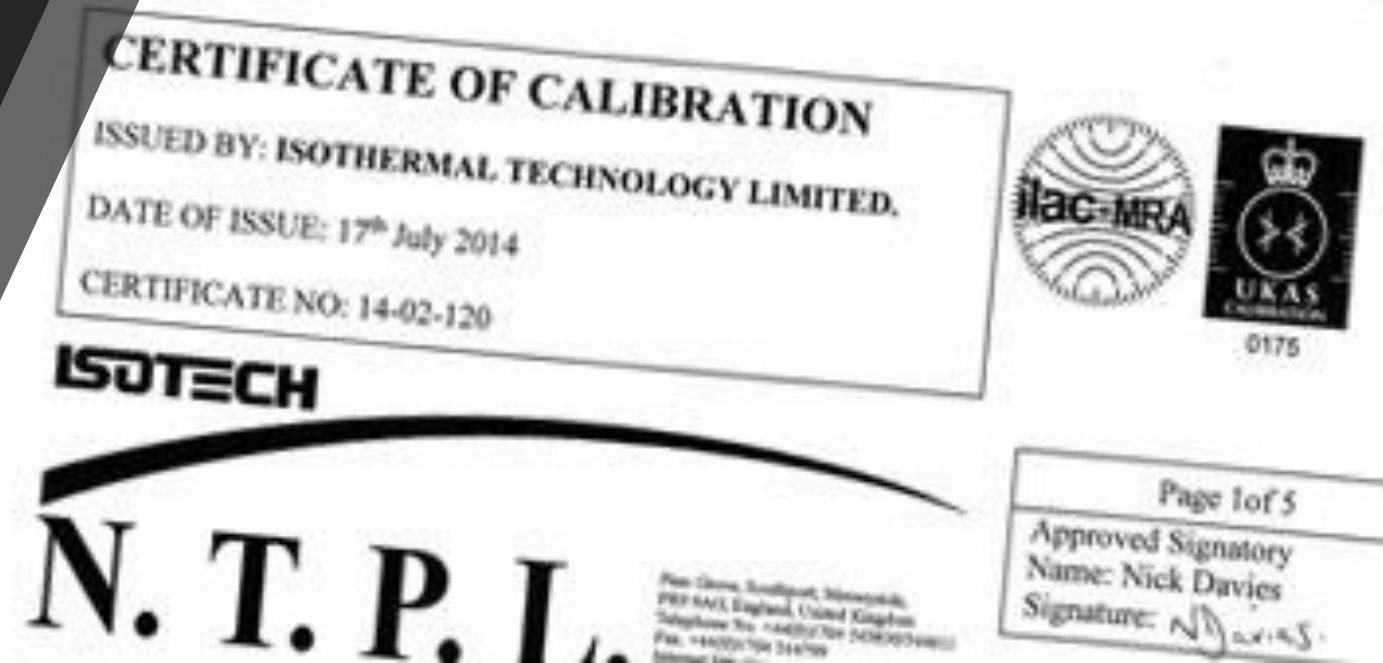
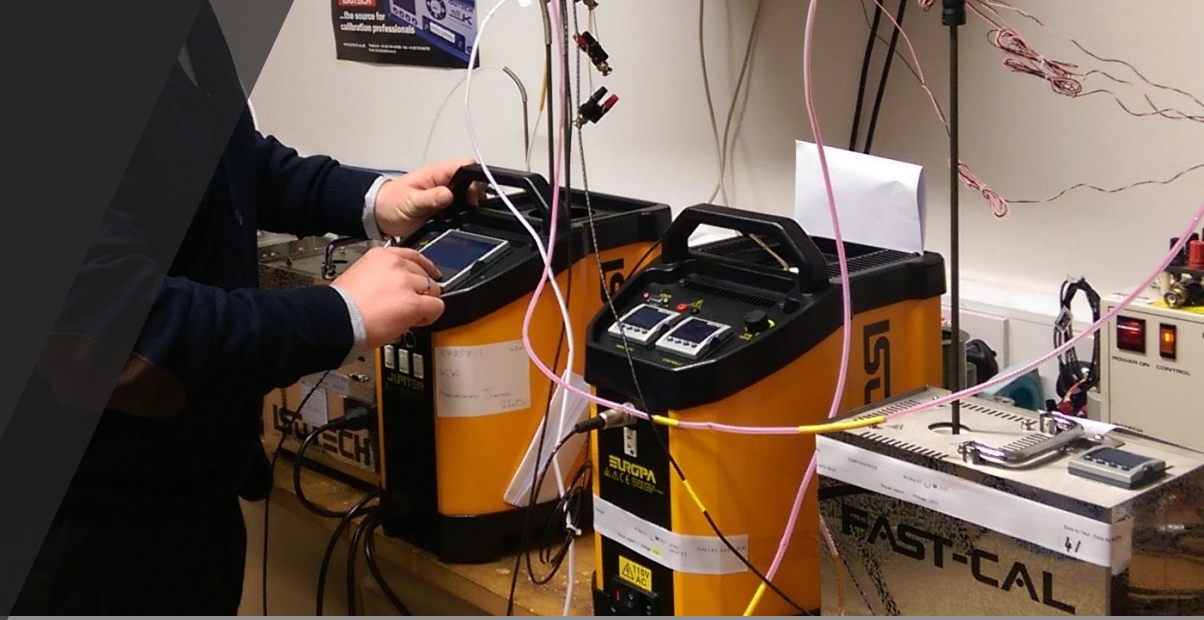

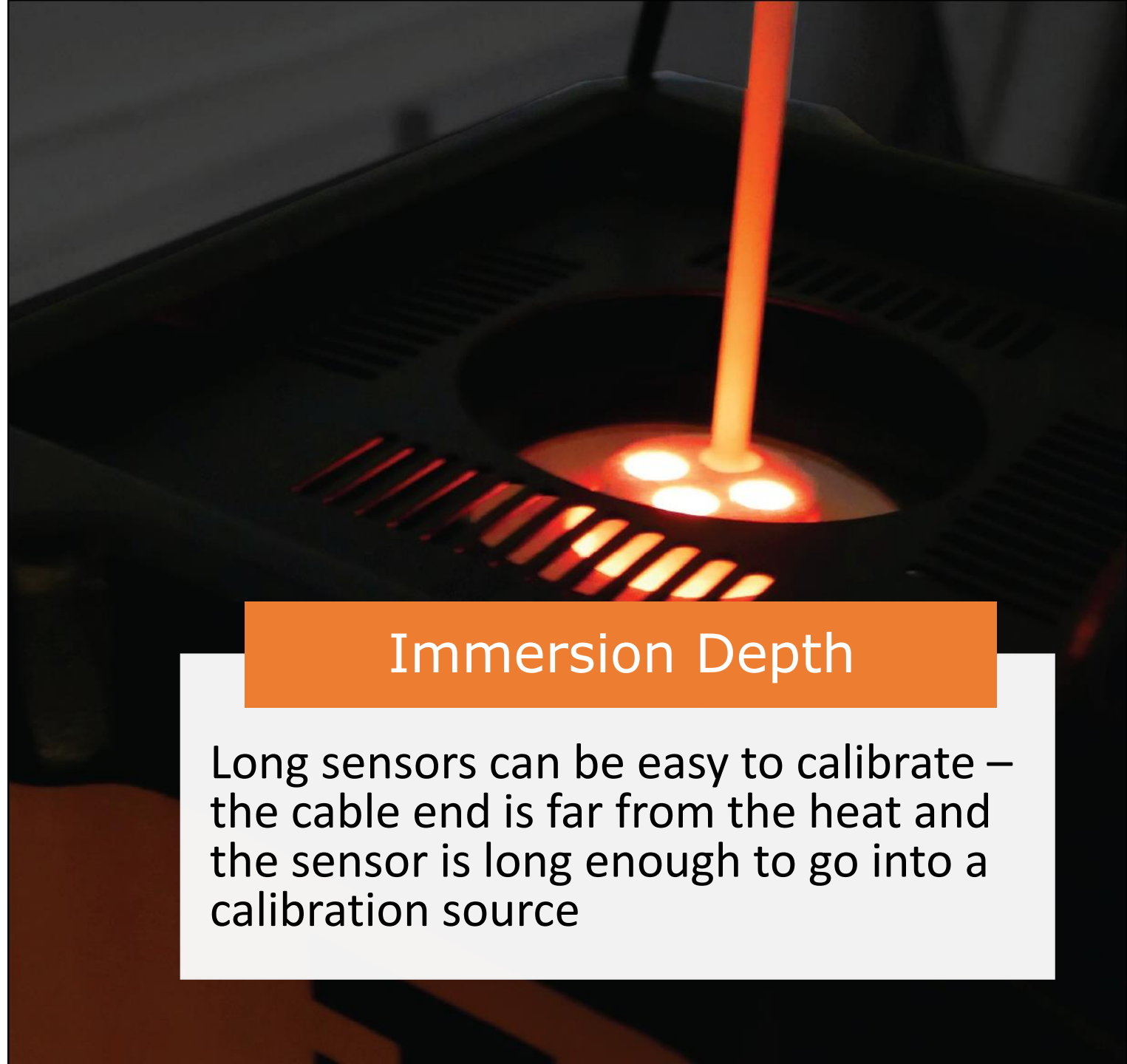

## Immersion Depth

Long sensors can be easy to calibrate – the cable end is far from the heat and the sensor is long enough to go into a calibration source



## Immersion Depth

**Short sensors can be very difficult to calibrate – too short for adequate immersion depth and risk of burn to the cable**

# Many Sensors are just too short to fit into standard calibration furnaces

Attempting to place a short sensor deeply into a furnace has major problems, the top of the sensor may not fit, or be overheated – the cable can be destroyed from the heat

Short sensors cannot simply be placed into conventional furnaces

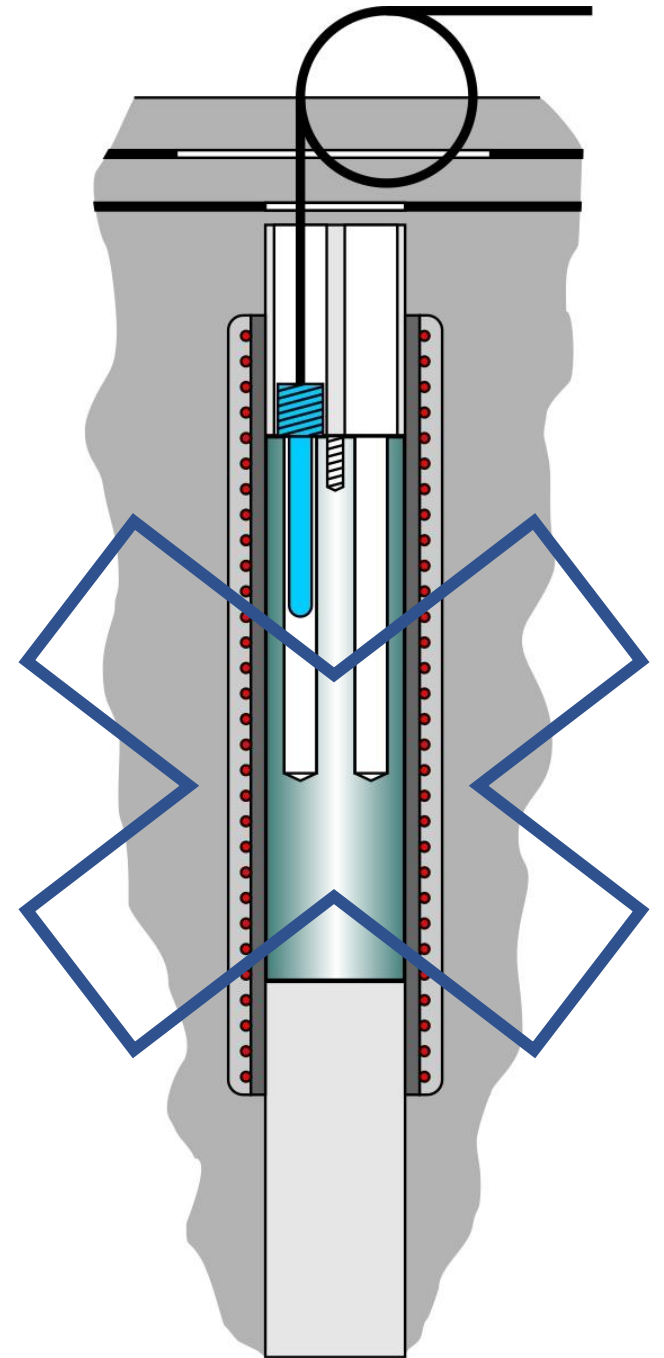

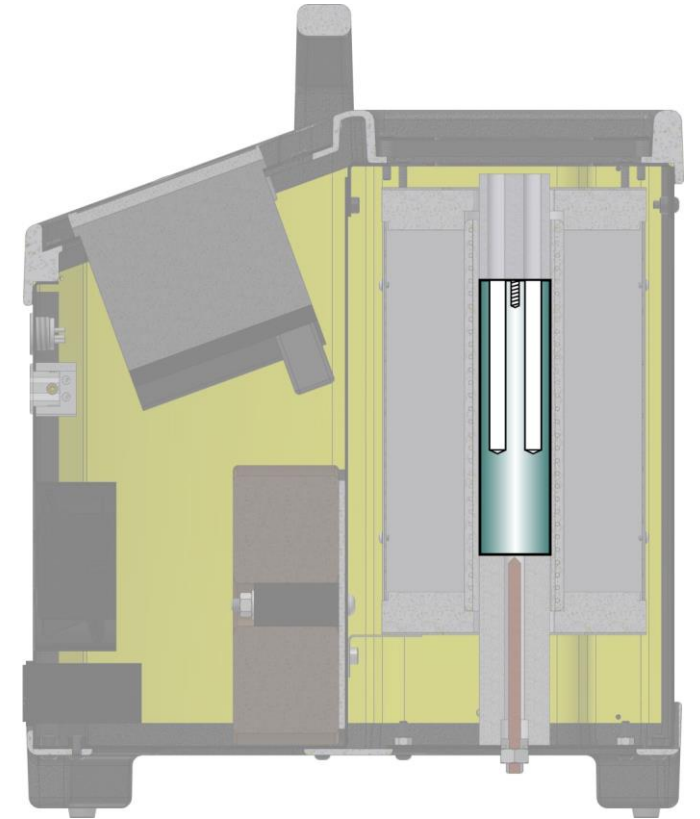
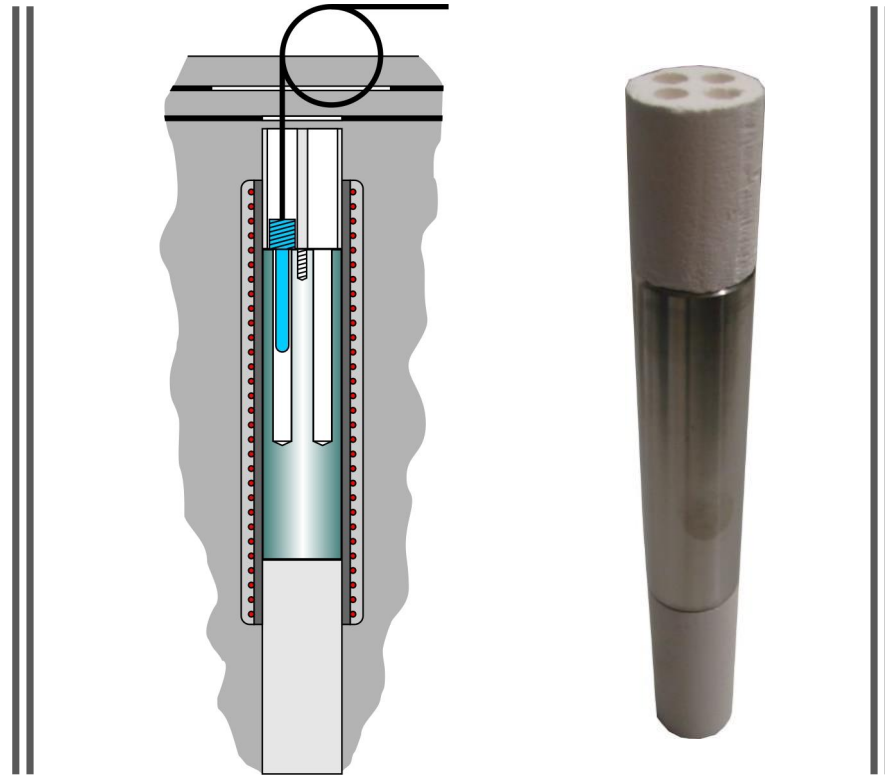

# Pegasus 4853 or Pegasus-T

The Isotech Pegasus 4853 is a solution for sensors > 130mm long  
Insert has 80mm immersion + 50mm insulation Effective 130mm immersion depth

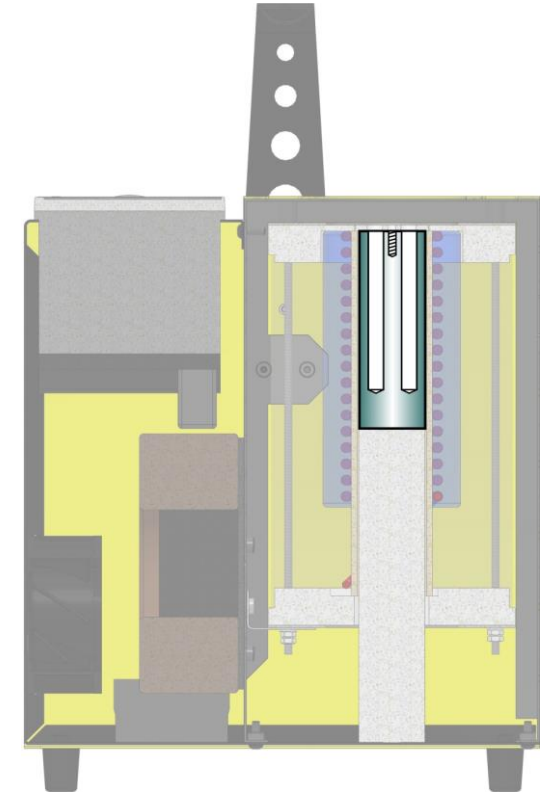
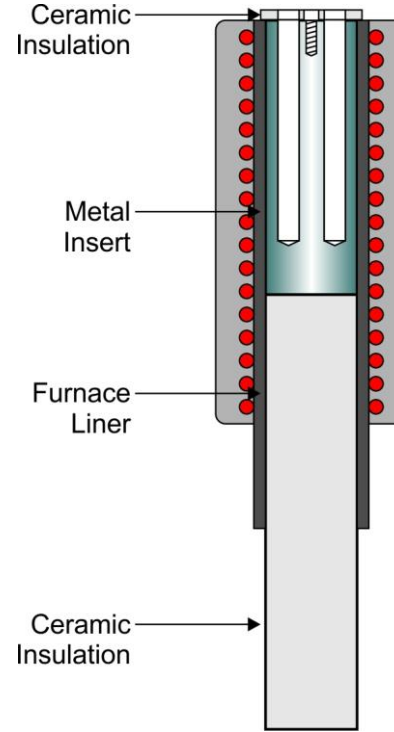

# Pegasus-T – for shorter sensors

The Pegasus-T can be used with much shorter sensors

# The Pegasus-T is optimised for short immersion

The new Pegasus-T has been developed for this very challenge and features a dynamic heating zone for short immersion probes providing a calibration source for sensors that are too short for other furnaces. It is being trialled and adopted at a number of customer sites in Europe and Asia and is now released for general sale

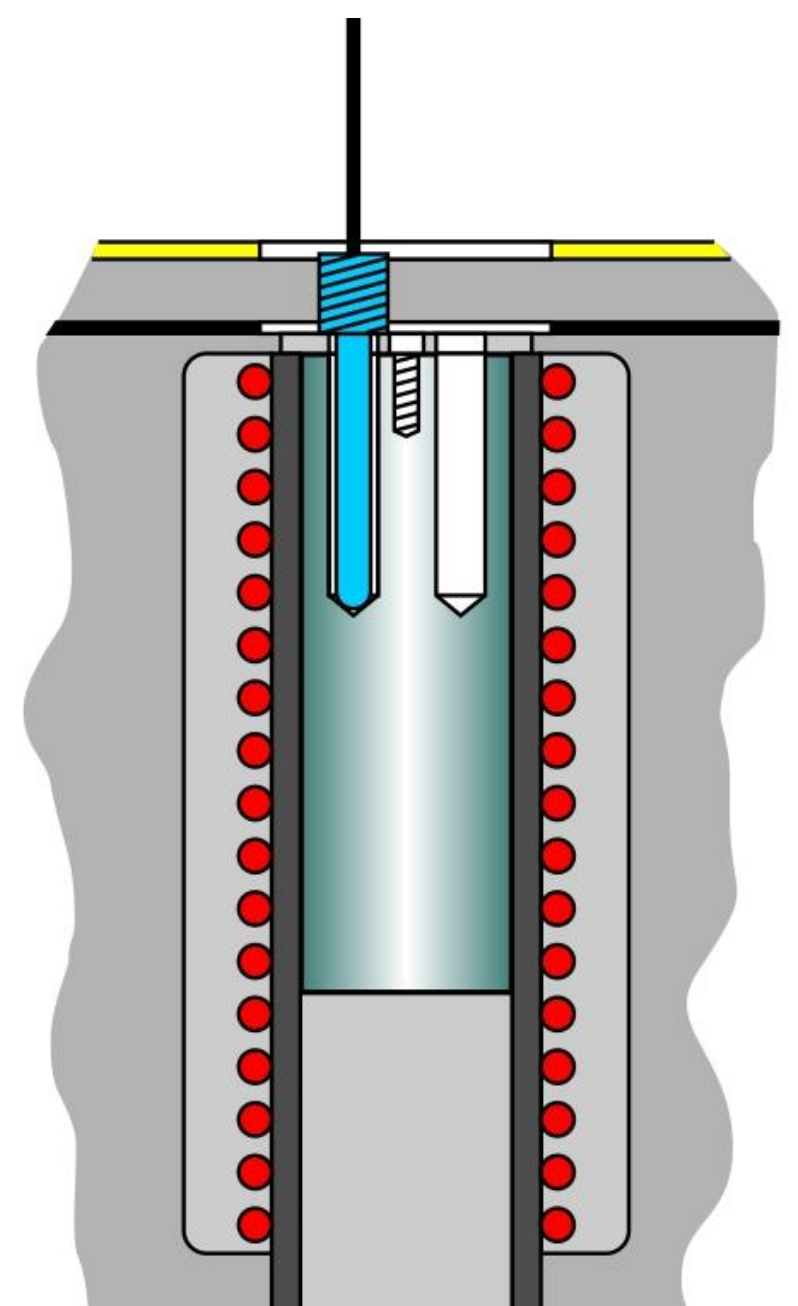

# Special Features of the Pegasus-T



# 1: Dynamic Heating Zone

Pegasus-T allows you to choose an internal control sensor at the same depth as that of the sensors under test

Choose from three internal noble metal control sensors to optimise performance at 25, 35 or 50mm

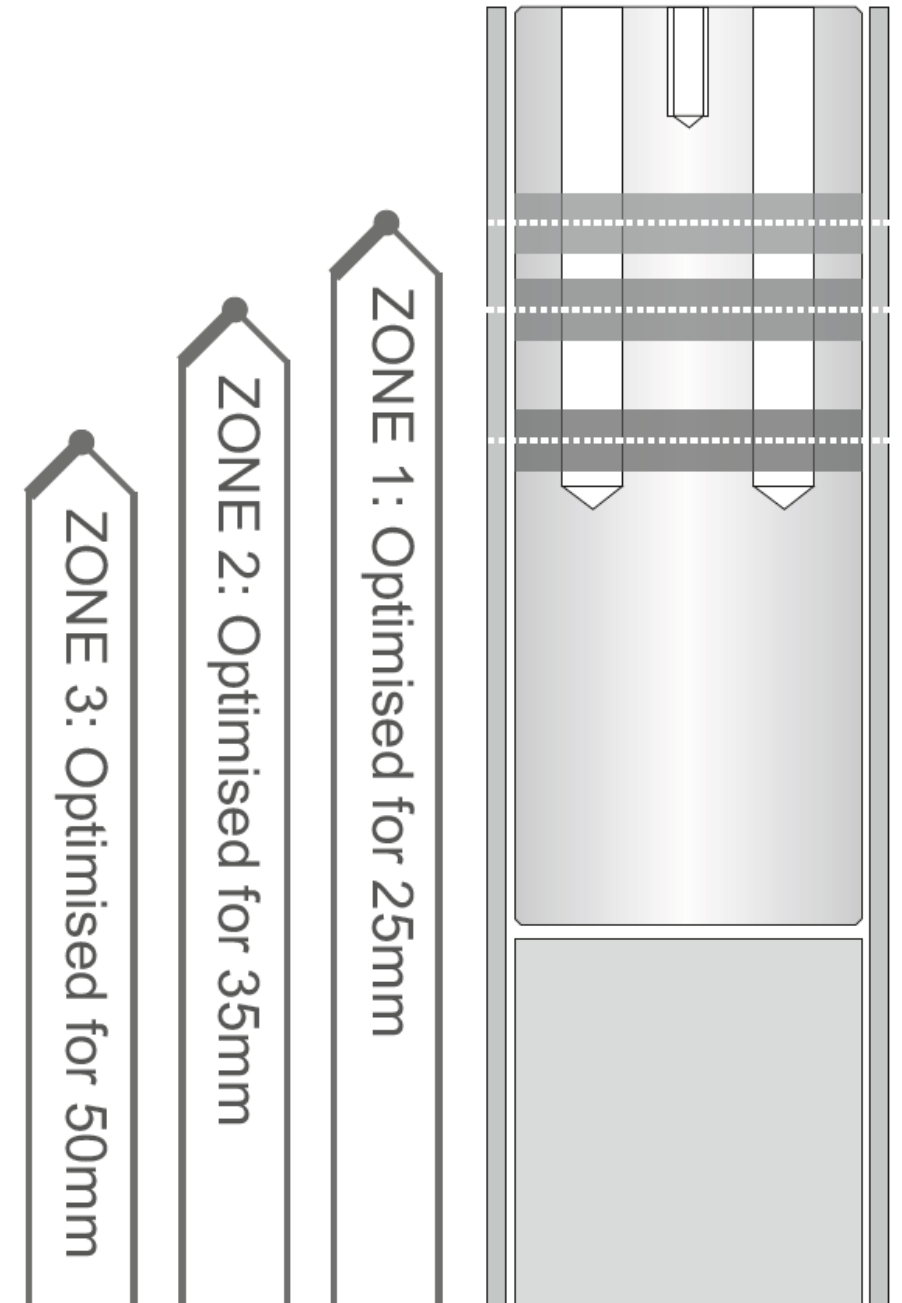

## 2: Control from External Sensor

Alternatively use an external control sensor placed at the same depth as the sensor under test

A Type R Sensor, Model 935-14-91 is included with each Pegasus-T



### 3: Advanced Features

Fully featured high resolution display with advanced control features including multi loop control with autotune, adjustable temperature alarms with control from internal or external thermocouples



# Advanced Features

## Temperature Programmer

Create, Edit and Store automatic programs for temperature stepping



# Advanced Features

## Ethernet Interface

### With free logging software

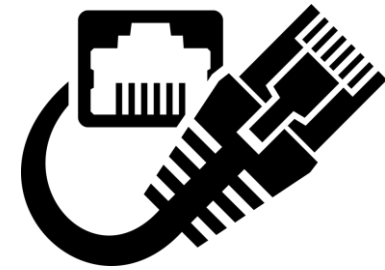

# Advanced Features

## USB Interface

Export logged data to a USB Key,  
controller data is continuously  
logged



# Advanced Features

## Offset Elimination

Connect the external reference probe and the calibrator can trim the block temperature to remove offsets

- Block adjusted to reference probe value
- Remove offsets
- Use in combination with automatic cycling

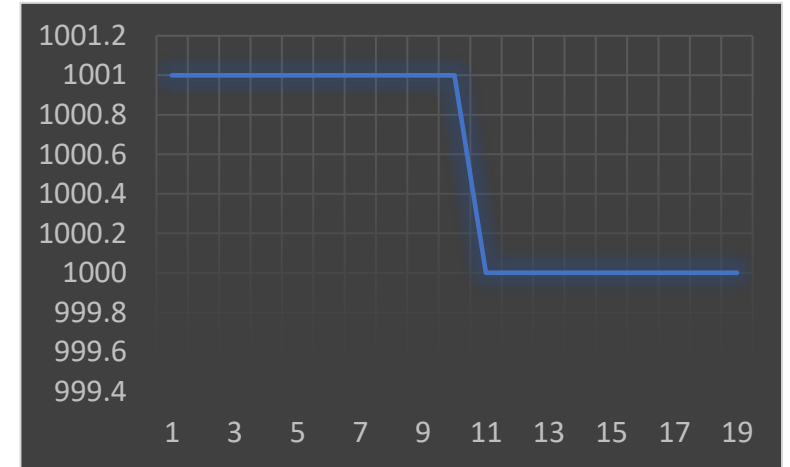

# Inserts

The test sensors are placed into interchangeable metal inserts

The Pegasus-T does not include an insert as most applications are bespoke

Options are for an insert with, 6 x 5mm pockets, a blank insert for you to machine or we can offer custom drilled inserts

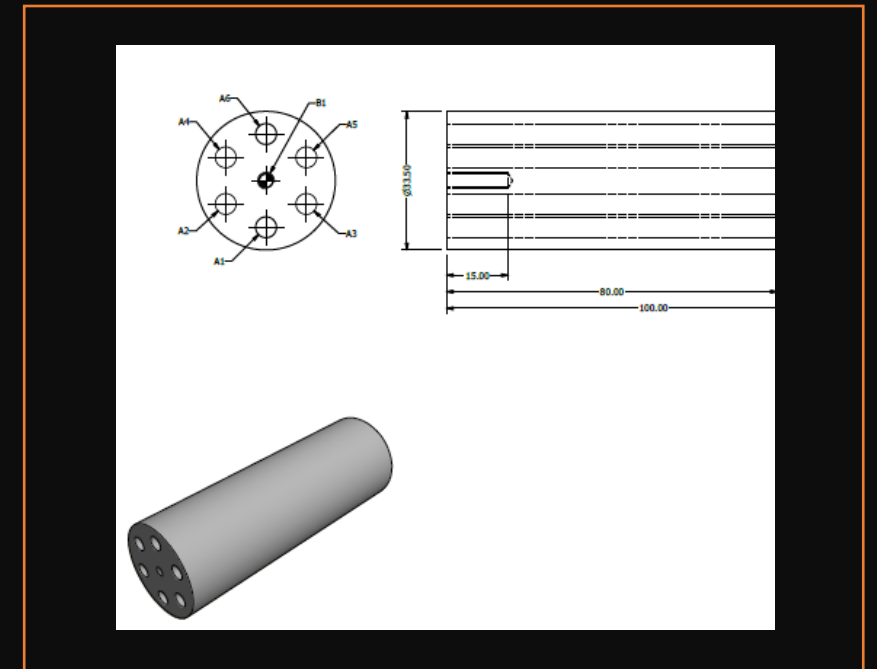
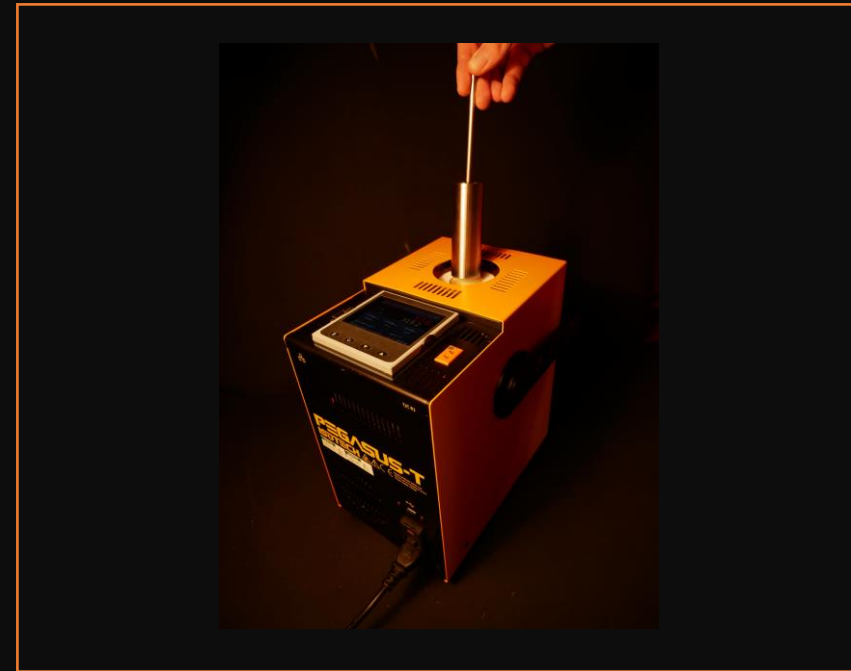

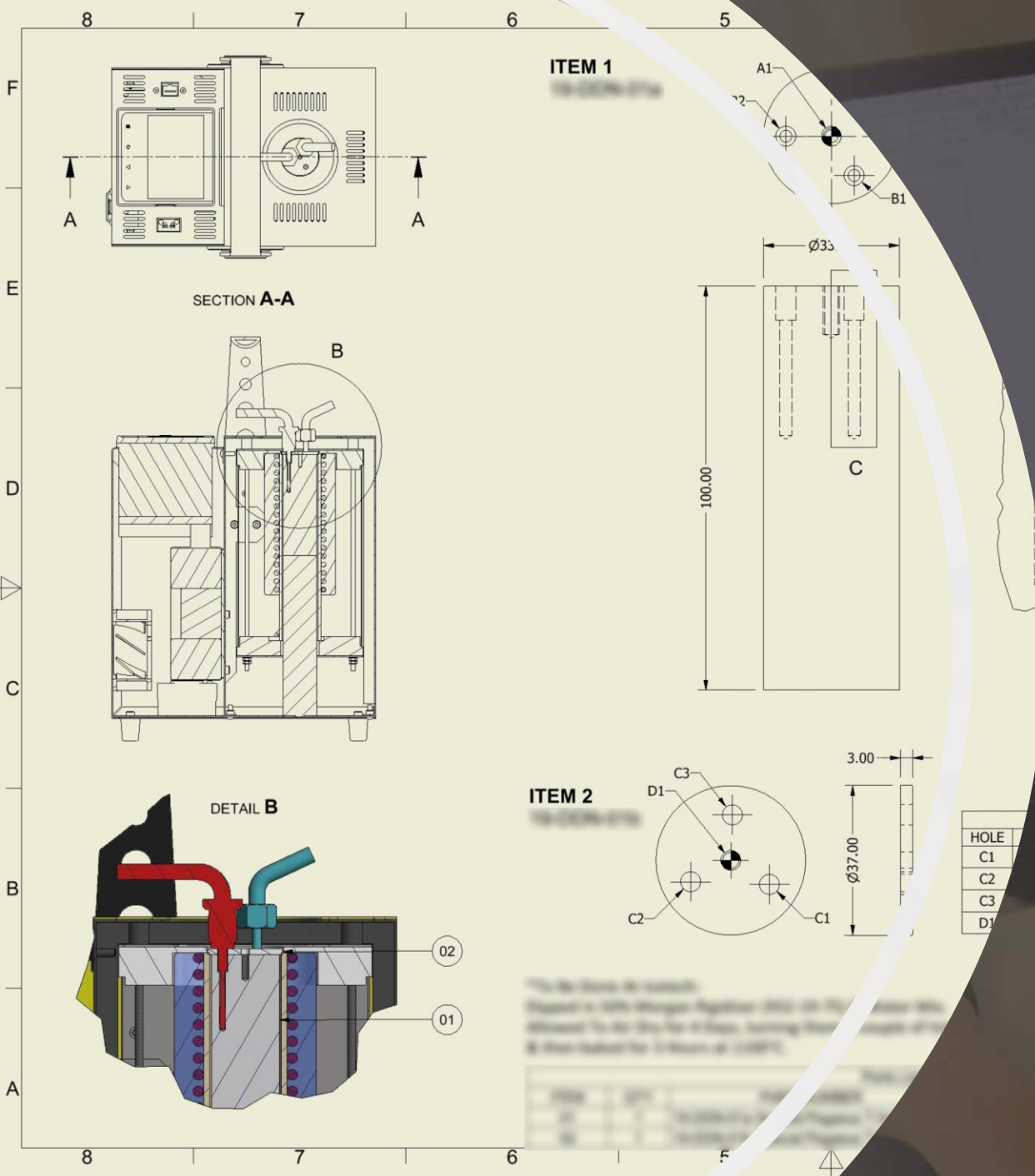

# Insert Design

Our CAD engineers design application specific inserts





# Custom Inserts

---

Custom inserts are made in-house to offer you fast delivery and total quality

---

# Specifications

## Specifications:

Parameter	Pegasus-T
Temperature Range	150°C to 1100°C
Stability	±0.05°C at 150°C ±0.08°C at 1100°C
Display Resolution	0.1°C over whole range
Cools from 1200°C to 800°C	in 50 Minutes*
1200°C to 200°C	in 180 Minutes*
	*Substantially reduced by using the optional cooling adaptor
Heating Rate	25°C/minute
Calibration Volume	33.5mm Diameter by 100mm Deep
Automatic Temperature Cycling	Yes
PC Interface	Ethernet and USB Host
Independent Reference Channel	Yes: Can be used for external control or as a reference input
Datalogging	Yes: Export to USB
In Built Webserver	Yes
Indicator Units	°C, °F, K
Power	115Vac or 230Vac (50/60 Hz) 800 Watts
Dimensions	302H x 200W x 268D
Weight	13kg

NOTE: Due to our program of continual development and improvement, we reserve the right to amend or alter characteristics and design without prior notice

**Cautionary Note:** The operating life of the heater will vary with both the maximum operating temperature and the duty cycle. Units being used 24/7 at high temperatures may require a maintenance schedule for heater replacement

# A Note About “Accuracy”

With short immersion probes there can be large errors as the sensor cannot be immersed deeply enough to allow it to reach the same temperature as the calibration block and there is a temperature gradient at the edge of the block. Tests show that the Pegasus-T is more useful than alternatives but there will always be a need to experiment and evaluate to determine the uncertainty for the conditions of use. It can be helpful to use a reference sensor of the same type as the units under test

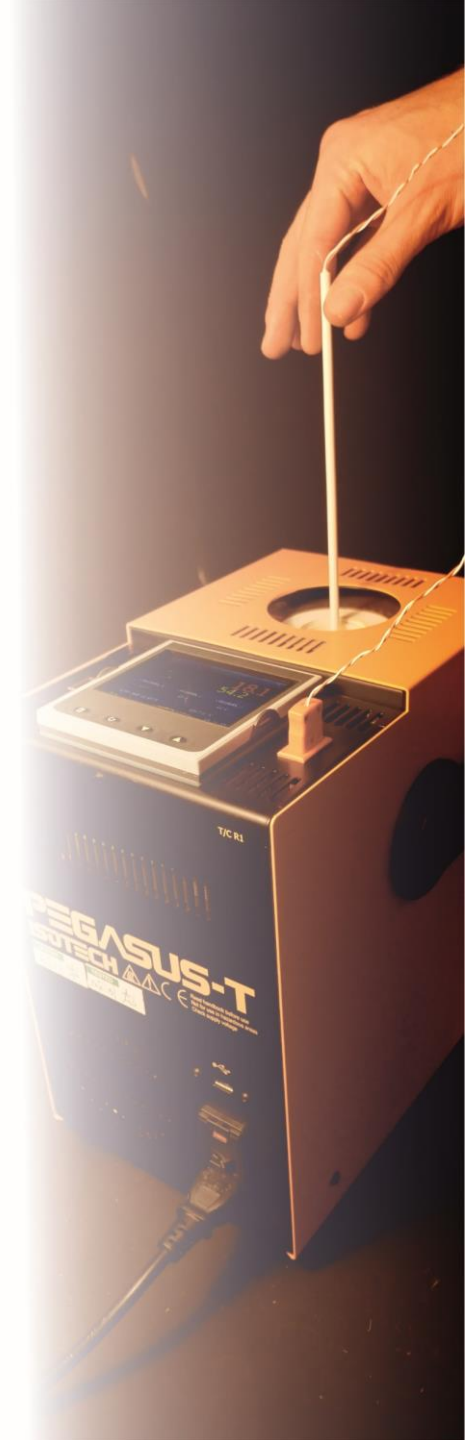
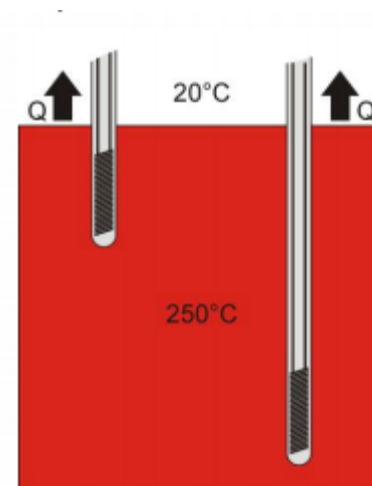

# Immersion Depth

Calibrating short stemmed sensors is always a challenge, *“The basis of accurate calibration is found in the Zeroth Law of Thermodynamics, the implication of which is that a sensor must be sufficiently immersed, such that further immersion makes no difference to the temperature reading of the thermometer”*

Short sensors cannot be immersed sufficiently to be at the same temperature as the calibration bath

With short sensors in a thermal gradient at the top of a calibration bath, large uncertainties result NOT from the bath performance but from inadequate immersion depth

Long stemmed thermometers can be immersed deep enough to be in thermal equilibrium with the calibration bath – and for the cable end of the thermometer to be away from extremes of temperature

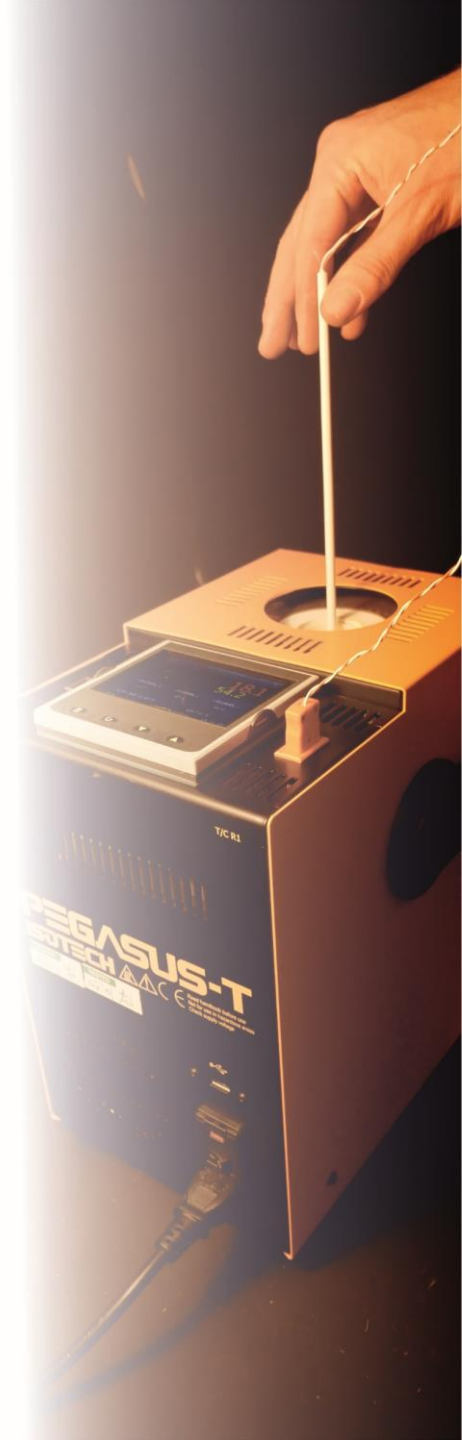



## Heater Lifetime

**Cautionary Note:** The operating life of the heater will vary with both the maximum operating temperature and the duty cycle. Units being used 24/7 at high temperatures may require a maintenance schedule for heater replacement

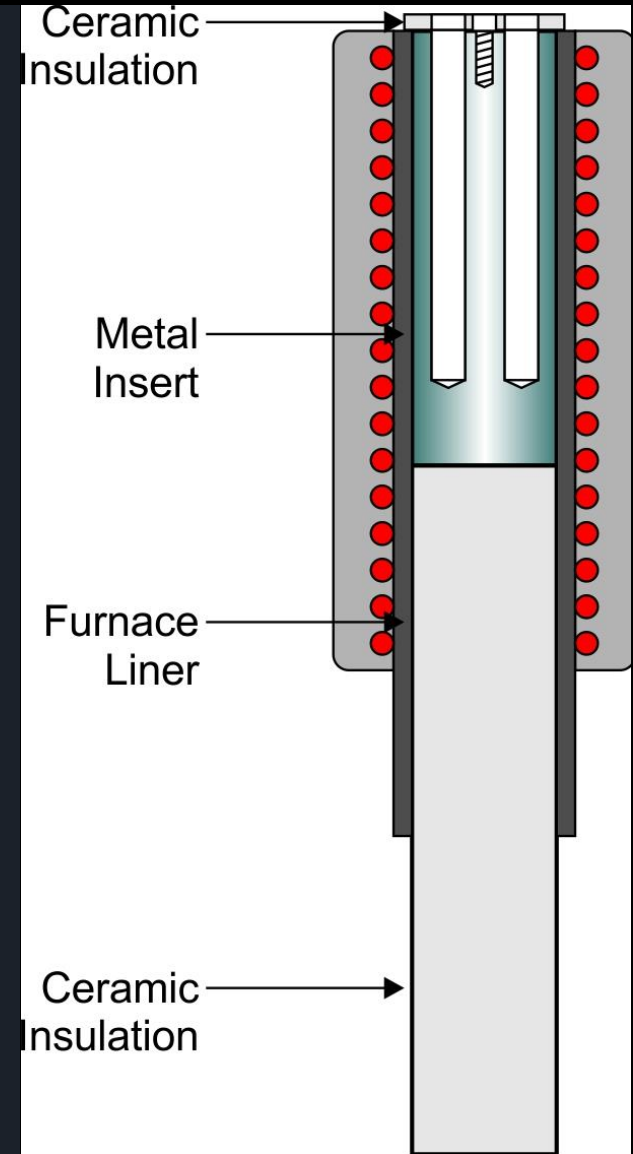

# Why Choose Isotech?

Innovation

40 Years of Experience

Designed and Built in the United Kingdom

UKAS Accredited



# Further Information

Isotech Industrial Calibrators

<http://isotech.co.uk/industrial>

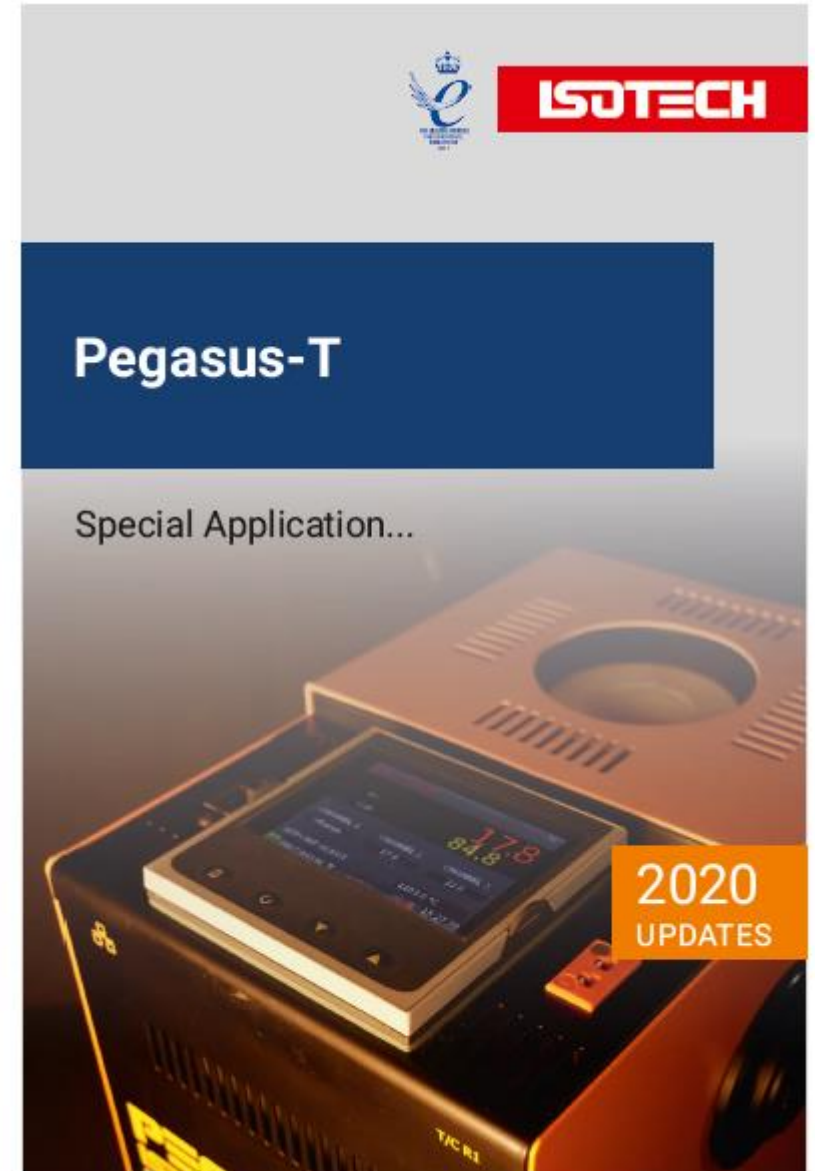



**ISOTECH**

World Leader in Temperature Metrology